



TCW450

Surface / suspension mounted waterproof luminaire suitable for single and twin TL-D 36 Watt and TL-5 28W / 54W. Designed for applications in demanding operating environments. TCW450 is dust, jet and shock proof luminaire for TLD and TL5 lamps is a perfect solution for moist and dusty conditions. TCW 450 has Polycarbonate housing and cover with all the accessories mounted in a CRCA Gear Plate. The ribbed Polycarbonate cover provides better light distribution. The luminaire offers the flexibility and ease of installation.

Features

- Polycarbonate housing and linear prismatic ribbed cover providing excellent distribution of light.
- Convenient Polycarbonate fastening clips and hinged diffuser to make it easy to replace lamps.
- Ingression protection of IP 65 for protection against dust and water. Option of electronic gear to provide flicker free and low cost operations.
- Press fit CRCA gear for ease of maintenance.

Application

- Industries
- Public parkings
- General interiors
- Dusty and wet environment

Related products



TCW450m

Dimensional drawing

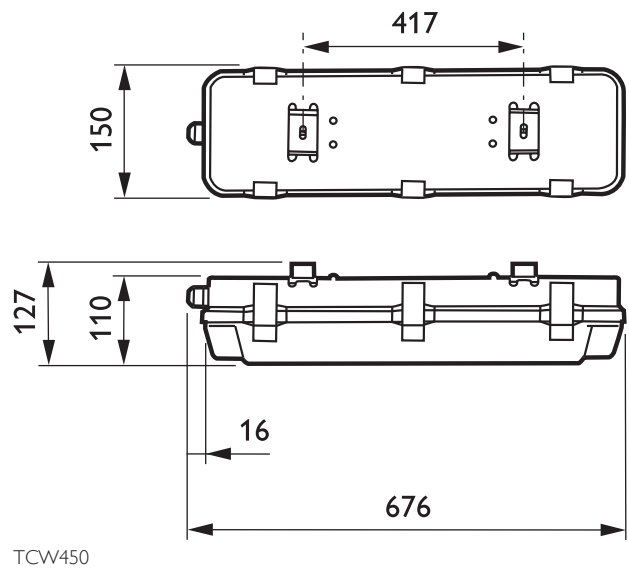
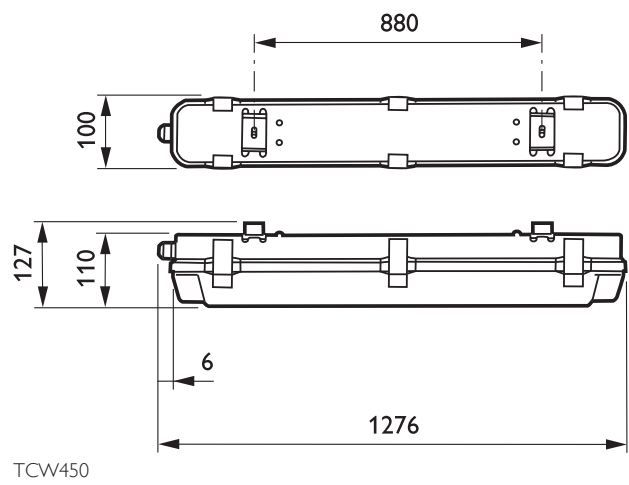
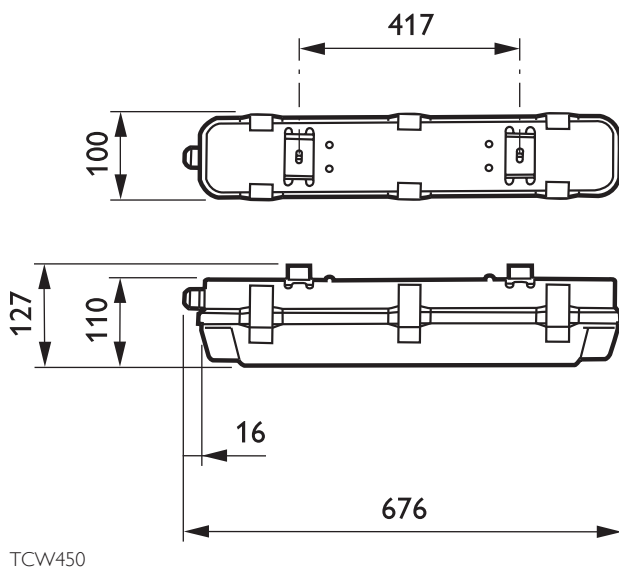

Dimensional drawing

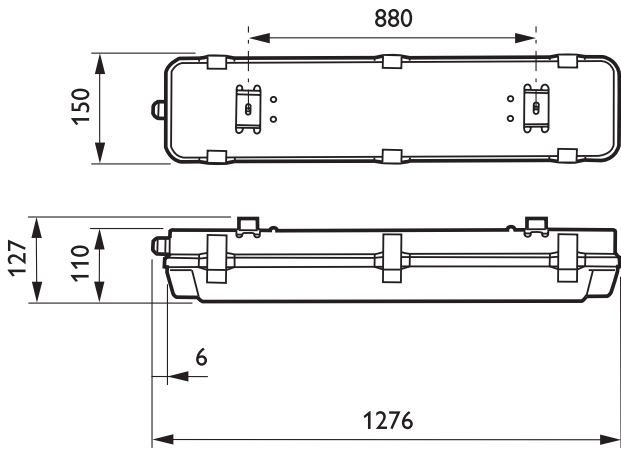

TCW450

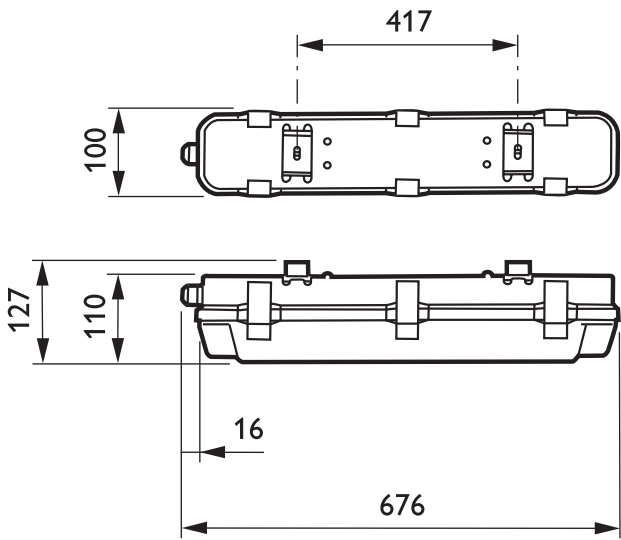

TCW450

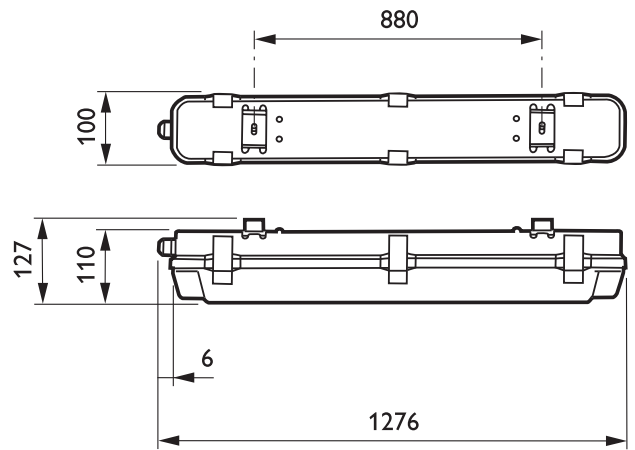

TCW450

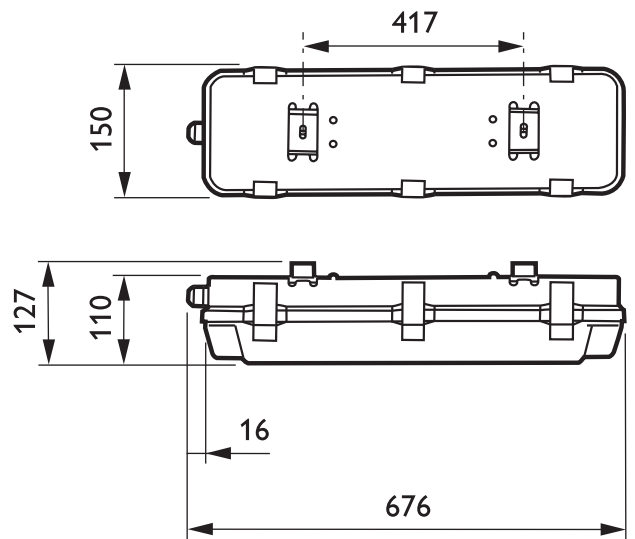

TCW450

Dimensional drawing

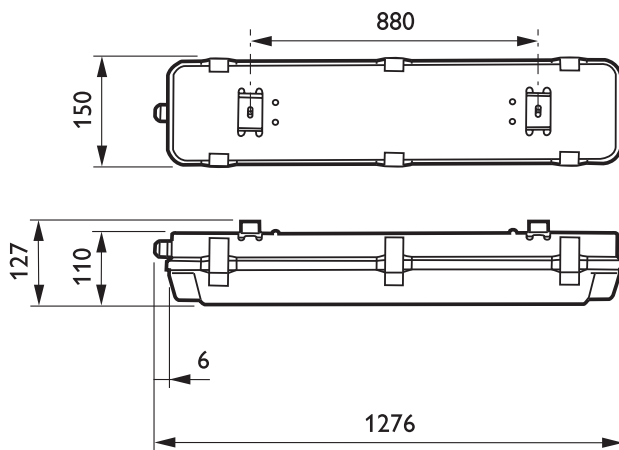

TCW450

General information

Order code	Product family code	Number of lamps	Lamp family code	Lamp power	Gear
919115810041	TCW450	1	TL5	28	EBS
919115810042	TCW450	2	TL5	28	EBS
919115810073	TCW450	2	TL-D	36	EBT

Order code	Product family code	Number of lamps	Lamp family code	Lamp power	Gear
919115810074	TCW450	1	TL-D	36	EBT
919615810147	TCW450	2	TL5	54	EBP



© 2012 Koninklijke Philips Electronics N.V.
All rights reserved.

Specifications are subject to change without notice. Trademarks are the property of Koninklijke Philips Electronics N.V. or their respective owners.

www.philips.com/lighting

2012, January 21
data subject to change